

CHAPTER 38

Mass Spectrometer Hardware for Analyzing Stable Isotope Ratios

Willi A. Brand

Max-Planck-Institute for Biogeochemistry, PO Box 100164, 07701 Jena, Germany
e-mail: wbrand@bgc-jena.mpg.de

Abstract

Mass spectrometers and sample preparation techniques for stable isotope ratio measurements, originally developed and used by a small group of scientists, are now used in a wide range of fields. Instruments today are typically acquired from a manufacturer rather than being custom built in the laboratory, as was once the case. In order to consistently generate measurements of high precision and reliability, an extensive knowledge of instrumental effects and their underlying causes is required. This contribution attempts to fill in the gaps that often characterize the instrumental knowledge of relative newcomers to the field.

38.1 Introduction

Since the invention of mass spectrometry in 1910 by J.J. Thomson in the Cavendish laboratories in Cambridge ('parabola spectrograph'; Thomson, 1910), this technique has provided a wealth of information about the microscopic world of atoms, molecules and ions. One of the first discoveries was the existence of stable isotopes, which were first seen in 1912 in neon (masses 20 and 22, with respective abundances of 91% and 9%; Thomson, 1913). Following this early work, F.W. Aston in the same laboratory set up a new instrument for which he coined the term 'mass spectrograph' which he used for checking almost all of the elements for the existence of isotopes. Aston not only confirmed the neon findings, he also discovered ^{21}Ne which has only a 0.3 atom-% abundance. During his scientific career, Aston discovered 212 out of the total 287 naturally occurring isotopes (Aston, 1942). This work brought new order into the periodic table of the elements which had previously been troubled by irregularities between atomic weight and chemical properties of the elements. Aston showed that the isotopic masses are not simple integral masses of a basic nucleon but rather that there is a mass defect that is related to the binding energy of the nuclei. Both J.J. Thomson and F.W. Aston were awarded Nobel Prizes for their achievements (Physics in 1906 and Chemistry in 1922, respectively).

In general, a mass spectrometer is used to make a quantitative assessment of the contents of a given sample. The quality of the analysis thus depends on the ability of the mass spectrometer to detect all components of a sample with the same constant

sensitivity, irrespective of the complexity and chemical nature of the sample. This ideal mass spectrometer does not exist. Instead, the contents of a given sample have to be transformed into something which can be manipulated, separated and detected. In mass spectrometry, ions serve this purpose. The ability to quantitate the contents of a given sample is facilitated if sample complexity is reduced through separation of the individual chemical components prior to the measurement. This principle has led to the extensive use of separation devices (chromatographs) combined with mass spectrometers (as detectors) in chemical analysis. This combination has more recently been used for determination of the stable isotope ratios of the bio-elements (C,N,O,S and H)(Brand, 1996), alongside the more familiar method of isotope ratio measurement by high precision comparison of purified gases in the dual inlet system.

A stable isotope ratio mass spectrometer consists of an inlet system, an ion source, an analyzer for ion separation, and a detector for ion registration. The inlet system is designed to handle pure gases, principally CO₂, N₂, H₂, and SO₂ but also others such as O₂, N₂O, CO, CH₃Cl, SF₆, CF₄, and SiF₄. Neutral molecules from the inlet system are introduced into the ion source, where they are ionized via electron impact and accelerated to several kilovolts, and then separated by a magnetic field and detected by Faraday cups positioned along the image plane of the mass spectrometer (Nier, 1940). The principles guiding the design and operation of each of these individual sections of the mass spectrometer are described and discussed in sequence.

38.2 Inlet System Design

Inlet systems for gas isotope mass spectrometers are rather simple and clean devices consisting of valves, pipes, capillaries, connectors, and gauges. Home made inlet systems are often made of glass, but commercially available inlet systems are mostly designed from stainless steel components that have no cavities. All components and surfaces are carefully selected for maximum inertness towards the gases to be analyzed. The materials used as components of the valves deserve special attention. The highest quality valves are of 'all-metal' design, with all wetted surfaces made either from stainless steel (the body and membranes) or from gold (the gaskets or seals and the valve seat).

The heart of the inlet system is the '*Changeover Valve*' (Figure 38.1). It was first described in 1947 by B.F. Murphey, who was studying thermal diffusion in gases. The Changeover Valve allows the inlet system to alternately switch within a couple of seconds between two gases which enter in turn into a vacuum chamber (e.g. the mass spectrometer). The gases are fed from reservoirs to the Changeover Valve by capillaries of around 0.1 mm i.d. and about 1m in length with crimps for adjusting gas flows at their ends (Honig, 1945; Nier, 1947; Halsted & Nier, 1950). While one gas flows to the vacuum chamber, the other is directed to a vacuum waste pump so that flow through the capillaries is never interrupted. Without capillaries, a flow directly from a reservoir through an orifice into the mass spectrometer would be a direct effusion into vacuum, which would result in a change in isotopic composition over time. The forward flow of gas in the viscous flow regime through the long capillaries prevents the isotopic diffusion profile from penetrating from the crimp back into the sample reser-

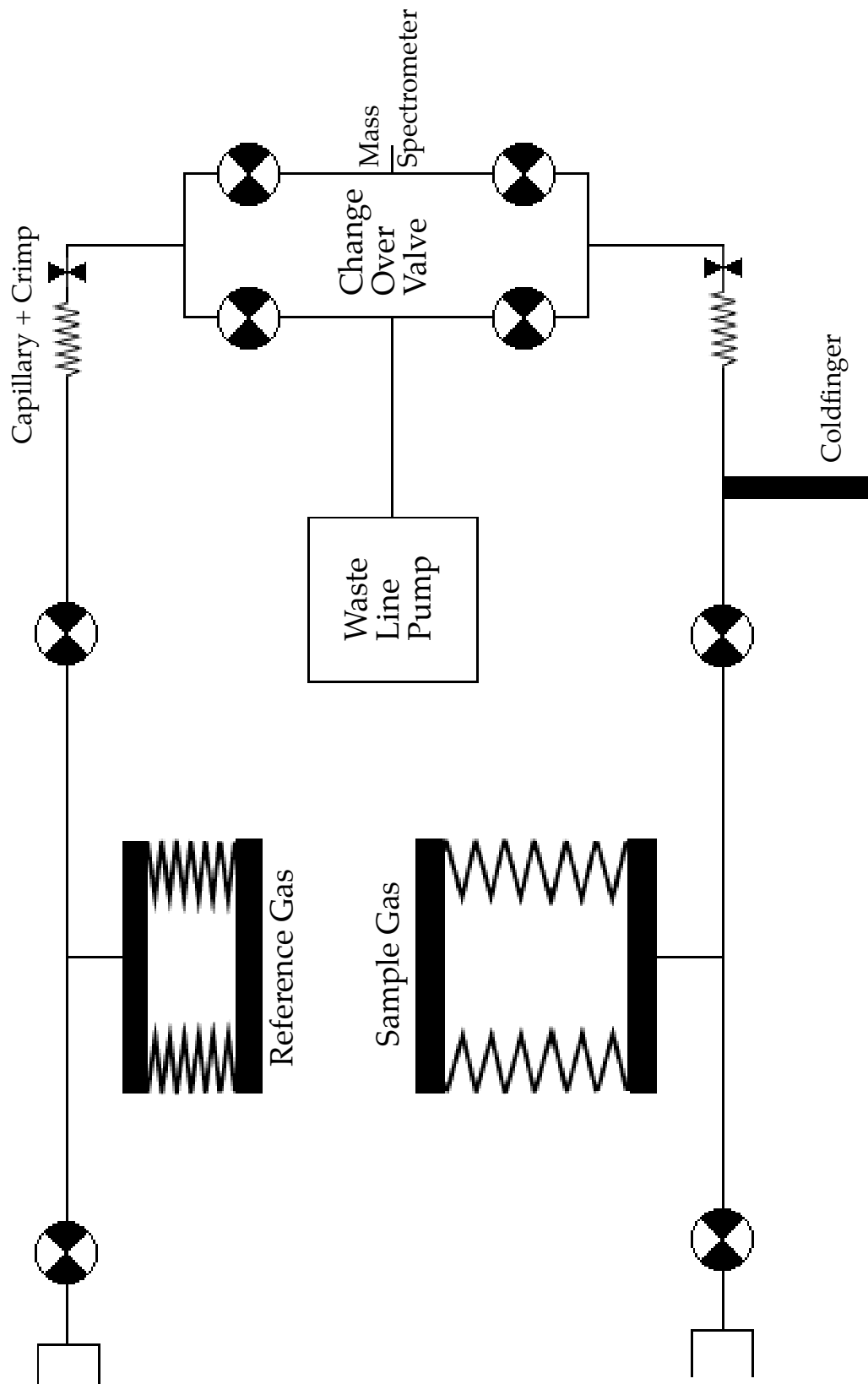

Figure 38.1 - Essential components of a 'Dual Inlet System' for gas isotope ratio mass spectrometry. For clarity the pumping infrastructure for the variable volume reservoirs and for the pipework has been omitted from the figure. The 'Changeover Valve' is an arrangement of four valves that allows gas from one reservoir to flow to the mass spectrometer while the other goes to waste. The design of the changeover valve deserves special attention in order to minimize cross talk between the gases.

voir (Halsted & Nier, 1950; Habfast, 1997). In 1950, C.R. McKinney et al. applied the Changeover Valve principle to isotope ratio measurements. With their system, McKinney and coworkers were able to measure the stable isotopes of oxygen in O₂ and of both carbon and oxygen in CO₂ with a precision of about 0.1 per mill (δ -notation¹). To achieve such high precision, instrumental drifts occurring during measurement need to cancel almost quantitatively. To achieve this goal, the gas reservoirs on either side of the Changeover Valve are normally stainless steel bellows (formerly, mercury pistons) that allow the ion current signals of the two gases to be precisely balanced. Any non-linearity, temperature dependence of electronic components, or changes in sensitivity of the ion source or the magnetic field thus tend to cancel. By comparing the two gases several times within minutes it was possible for McKinney et al. to achieve the reported high precision. The McKinney instrument provided the basis for the “classical” procedure for high precision stable isotope ratio measurements. Its principles have survived for 50 years with little change and they will provide the basis for ultimate precision isotope ratio determination into the foreseeable future.

The smallest amount of sample that can be analyzed using the dual inlet system is limited by the requirement to maintain *viscous flow conditions*. As a rule of thumb, the mean free path of a gas molecule should not exceed 1/10th of the capillary dimensions. With the capillary dimensions of 0.1 mm i.d., the lower pressure limit for viscous flow and thus accurate measurement is about 15 to 20 mbar. When trying to reduce sample size, it is necessary to concentrate the gas of interest into a small volume in front of the capillary. For practical reasons, such a volume cannot be made much smaller than 250 μ l. For condensable gases, it is shaped into a cold finger to be operated as a cryotrap at liquid nitrogen temperature under molecular flow conditions. Using the ideal gas law, the product of pressure and volume yields the smallest sample amount that can be accurately analyzed in a microvolume inlet system to be about 5 bar μ l or 220 nmol of clean gas.

Because real life samples rarely are the clean gas species used in the dual inlet system, each sample, be it a carbonate, a water sample, a lentil or a piece of tree ring, must be converted into the required simple gaseous form prior to analysis. There is a wide variety of specialized sample conversion and inlet systems including manually operated devices whose output must be manually introduced into the inlet reservoir and automated devices that deliver the final product gas directly to the inlet system under computer control. Other chapters in this book cover the various forms and experimental challenges of sample preparation for high precision isotope ratio determination.

1. $\delta [‰] = (R_{Sa}/R_{ref} - 1) \cdot 1000$

{for ¹³C: $R_{Sa} = {}^{13}\text{C}/{}^{12}\text{C}$ ion current ratio of sample gas}

[38.1]

38.3 The Ion Source: Electron Impact Ion Production

Wishful thinking:

If we could only sit and watch the molecules directly distinguishing their different weight through some colorful property, we could calculate isotope ratios just by counting¹. This would, however, be a tedious and time consuming task because of the large number of particles required for high precision.

38.3.1 Basic principles

Sample molecules enter the ion source of the mass spectrometer from the inlet system in gaseous form. Here, some of them are ionized by bombardment with electrons (*Electron Impact, EI*):



The efficiency of this process determines the sensitivity of the mass spectrometer. It depends on the ionization cross section, the number of electrons, and the number of molecules presenting themselves to be ionized. Following ionization, the $M^{+\bullet}$ molecular radical cation can further fragment into several pieces (e.g. $\text{CO}_2^{+\bullet} \rightarrow \text{CO}^+ + \text{O}\bullet$), depending on the internal energy the ion has acquired during the ionization process and the possible reaction pathways. The result of such unimolecular reactions is the mass spectrum of a chemical compound. More specifically, the fragments that form in the ion source within about one microsecond following ionization comprise the mass spectrum. Later reactions give rise to what we refer to as 'metastable' ions. As an example, there is a broad peak at mass 17.8. $\text{CO}_2^{+\bullet}$ molecular ions which were accelerated as mass 44 but decayed to CO^+ (mass 28) in front of the magnet arrive at the detector plane at mass position $m^* = m_2^2/m_1$. Here, m^* is the apparent mass position (17.8), m_2 and m_1 are the mass positions of the daughter (28) and parent ion (44), respectively.

38.3.2 Ion Source Schematics

Figure 38.2 is a schematic representation of an electron impact ion source. Electrons are released from a hot filament made from tungsten, rhenium or thoriated iridium and accelerated by electrostatic potentials to an energy between 50 and 150 eV before entering the ionization box. Their velocity, v , can be calculated according to:

$$v = \sqrt{2eU/m} \quad [38.3]$$

where e = elementary charge, U = accelerating potential, m = mass of the particle.

The velocity of 100eV electrons is about $6 \cdot 10^8$ cm/s. Thus they traverse the ion box in about 2 nanoseconds. The molecules appear virtually motionless because they

1. To avoid confusion: Ion counting is also a special technique using fast secondary electron amplifiers with amplification up to 10^8 together with time and threshold discrimination techniques. It indeed is a powerful tool e.g. for measuring small abundances of isotopes in thermal ionization mass spectrometry.

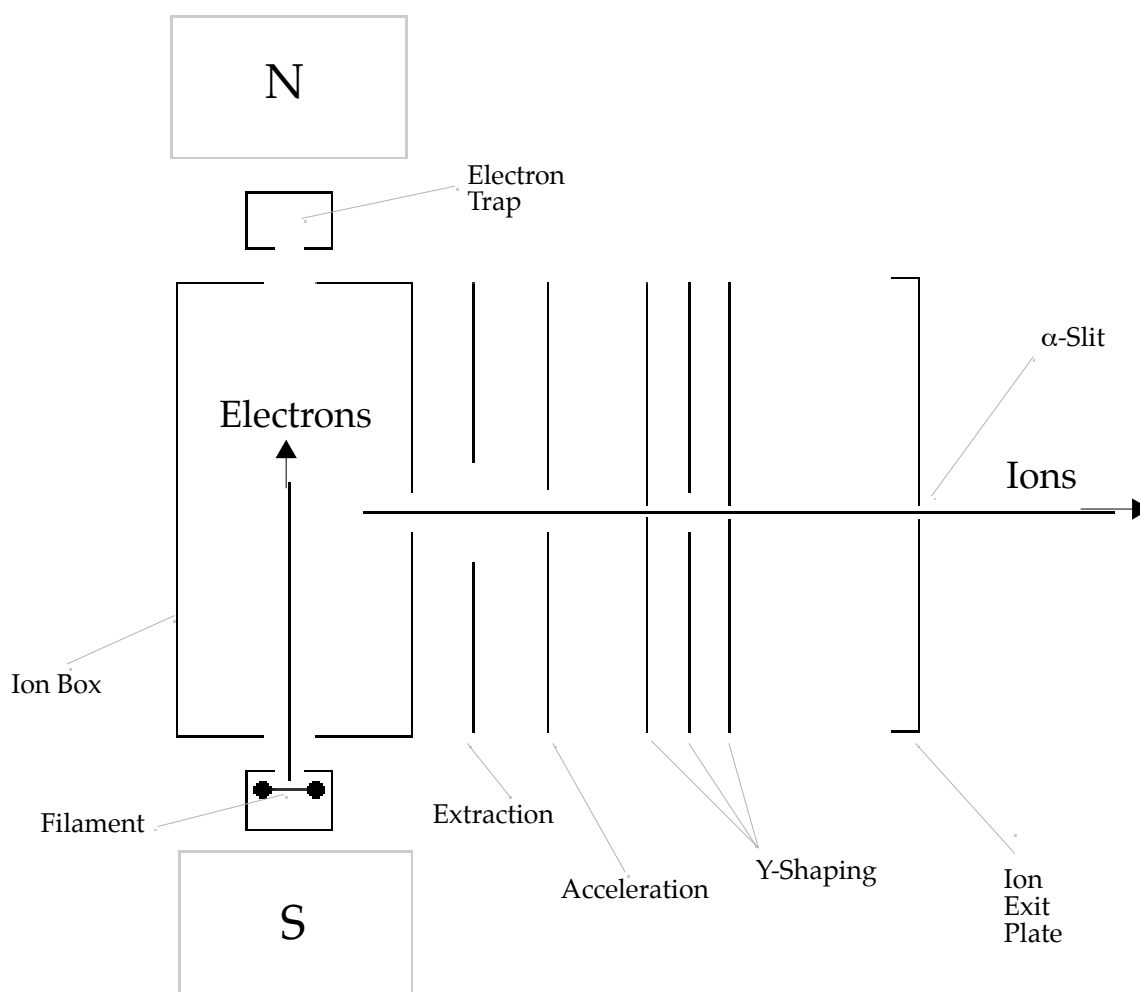

Figure 38.2 - Schematic layout of an Electron Impact (EI) ion source for gas isotope ratio mass spectrometry. The insulating spacers that also provide an enclosure for the whole source are omitted for clarity.

are moving in the ion source at thermal velocities of only about $3 \cdot 10^4$ cm/s.

A homogeneous magnetic field of 100 to 500 Gauss is used to keep the electrons on a spiral path (to increase the ionization probability) through the ionization box effectively confining the ionization region to a diameter of <1 millimeter. At the end of the ion box, the electrons hit the electron collector or “trap”, sometimes after a gentle post-acceleration. The electron current at the trap is measured and is kept constant by the emission regulator circuitry. The properties of the emission regulator are important when making peak area measurements which are converted into abundance measurements of weight %C and %N).

Ions are extracted from the ion box perpendicular to the direction of the electron beam by a field generated by either a repeller potential inside the ion box, an outside extraction lens, or a combination of the two. In order to minimize the translational energy spread of ions entering the ion optics of the mass spectrometer, the voltage

drop across the ionization region should not be too large. On the other hand, the potential gradient across the ionization region should not be too small either because ion-molecule reactions need to be suppressed by a fast acceleration out of the ion box. Ions are rather reactive chemical species. They like to react, for instance, with hydrogen-bearing molecules to form protonated MH^+ ions. This is particularly important in isotopic analysis because these ions fall onto the same mass positions as the isotopic species of interest at the $m+1$ mass position. For instance, an isobaric interference from $^{12}C^{16}O_2H^+$ is collected at m/z 45, which should be $^{13}C^{16}O_2^+$ and $^{12}C^{16}O^{17}O$ exclusively. Likewise, for hydrogen isotope ratios, H_3^+ ions (mass 3) hit the detector plane exactly where the Faraday cup for collecting HD^+ ions is mounted.

After extraction from the ion box, the ions are further accelerated and shaped into a beam which passes through the ion exit slit into the analyzer. Mass 44 ions with 5 keV translational energy will travel through the analyzer with a speed of $1.5 \cdot 10^7$ cm/s, hitting the detector after just a few microseconds.

38.3.3 Ionization efficiency

In modern isotope ratio mass spectrometers, the electron emission current is typically around 1 mA or $6 \cdot 10^{15}$ electrons per second moving through a cross sectional area of about 1 mm². With a typical ionization cross section (Kiser, 1965; Platzner, 1997) of about $3 \cdot 10^{-16}$ cm² or 3 Å² and the given geometry of the ionization region, the number of ions produced per second and thus the maximum sensitivity can be calculated (example):

Length of ionization region	= 10 mm
Cross section of ionization region	= 1 mm ²
Density of gas at 10^{-7} mbar: (flow = 1 nmol/sec)	= $2.7 \cdot 10^{12}$ particles/l = $2.7 \cdot 10^7$ particles in ion volume
Total ionization cross section in volume: ($2.7 \cdot 10^7$ particles x $3 \cdot 10^{-14}$ mm ²)	= $8 \cdot 10^{-7}$ mm ²

Thus, out of a total cross sectional area for the electrons of 1 mm², only $8 \cdot 10^{-7}$ mm² will typically be effective for ionization producing an ion current of $8 \cdot 10^{-10}$ A from a 1 mA electron emission current.

In order to improve on gas utilization, the pressure in the ion source is raised by using a 'closed source' design. The sole openings in such a source are the entrance and exit holes for the electrons and the exit slit for the ions. The rest of the source is gas tight which enhances the number of neutrals in the ion volume by a factor of about 100 resulting in an ion current of $8 \cdot 10^{-8}$ A or 80 nA in the example given. In practice, not all ions produced enter the mass spectrometer and reach the detector. The burn marks visible on the ion exit slit and on the aperture in the flight tube are traces of those ions that do not make it into the detector. Also, molecular ions that fragment in the ion source are lost for the isotopic analysis. Overall, an allowance for roughly 50%

loss must be made. Concluding the example: Out of the total flow of about 1 nmol gas per sec, an ion current of 40 nA is created. This corresponds to $2.5 \cdot 10^{-11}$ ions from $6 \cdot 10^{14}$ molecules or 2400 molecules are needed for one ion at the detector.

Typical sensitivity specifications of commercially available stable isotope mass spectrometers are 1000 to 2000 molecules per ion.

38.3.4 Problem areas in ion source design

The major objectives in isotope ratio mass spectrometry include:

- a linear relation between the ion current intensities and the measured ratios
- no memory between subsequent introductions of sample and reference gases in the mass spectrometer. Memory sources include gas adsorption on welds, copper gaskets (SO_2) and polymer gaskets (CO_2 , H_2)
- chemical inertness of the hot filament
- highly stable ion currents over a time range much longer than required for the measurement of a single sample

Some of these requirements are challenging and not all of them have completely met the satisfaction of the analyst. Some are very difficult to tackle.

1. Deviations from linear behavior can come from chemical or physical effects in the ion source. The major source of chemical non-linearity is the appearance of protonated species at the same mass position as the ion of interest due to incomplete suppression of ion-molecule reactions. The keys to avoiding this problem are rapid extraction of ions from the ion volume and utmost cleanliness of the samples. Where unavoidable, exact quantitative measurement of the effect is necessary in order to correct for it (e.g. H_3^+ correction for deuterium measurement). The presence of the collimating magnetic field in the ion source can lead to non-linear ratio response. If it is too strong, the field can lead to dispersion of the ions at the entrance slit prior to entry into the analyzer. Changing the number of ions influences the space charge in the ion source and thus the extraction conditions. As a consequence, the amount of pre-dispersion can vary with signal height. This physical effect scales with the relative mass difference, e.g. for CO_2 the 46/44 ratio shows a larger deviation than the 45/44 ratio. It can only be avoided by careful design of the ion optical components of the ion source. This is a major challenge for designers of mass spectrometers.

2. It is important to minimize the time required for gas exchange. The very high precision required for a number of investigations makes fast comparisons between sample and standard a necessity. During gas exchange the ion currents do not contribute to the measured signal. Possible changes in instrument response can be best compensated for by fast gas exchange. On the other hand, any gas left over after an analysis will mix with the new sample and will thus adulterate the measured isotope ratio. The measured difference in isotopic composition will be smaller than the true difference ('eta effect').

Some gases exchange easily (N_2 , N_2O , H_2), while more polar molecules are more “sticky” (CO_2 , SO_2) due to enhanced surface activity. For sulfur isotope ratio measurements, some mass spectrometers have a window in the closed ion source which can be opened and closed from the outside to enhance the pumping speed. The quality of the wetted surfaces, the avoidance of dead volumes that cannot be efficiently pumped and thus act as virtual leaks, and the minimization of surface area that is sputtered by charged particles must all be taken into consideration to ensure proper gas exchange behavior. Similar considerations also apply to the changeover valve and the connection to the ion source. The latter should be short and wide, i.d. 4 mm or larger.

The ion source should be chemically inert with respect to the analytical gases. Welds for instance have been identified as contributors to chemical memory and reactivity. Thus, wetted surfaces should be weld-free wherever possible. Several gasket materials have been identified as significant contributors to chemical memory (e.g. Cu gaskets in the analysis of SO_2). They can also act as virtual leaks (e.g. polymers with microporosity).

3. The hot filament can alter the gas composition in the ion source. Reaction of CO_2 with the hot tungsten for instance will form carbides that can be partly burned off when an O_2 pulse enters the ion source. The CO_2 released by this reaction typically has a rather positive $\delta^{13}C$ value as can be seen in chromatographic runs when oxygen enters the ion source as a pulse. In addition to carbide build up, tungsten oxide is formed at the filament surface by interaction with CO_2 , O_2 or H_2O . When the instrument is switched from carbon dioxide to hydrogen measurement, it is observed that ion currents and isotope ratios need some time (up to one hour) to stabilize. This is a consequence of reaction of hydrogen gas with the filament. Hydrogen reacts with the oxide layers on the filament to produce traces of water that temporarily give rise to extra H_3^+ ions at mass 3. Once the filament is conditioned for the gas to be measured, a steady state is reached with no further interference with the isotope ratio determination.

4. In order to reliably measure isotope ratios, ion currents need to be highly stable. More specifically, the conditions in the ion source need to remain optimized for ion production and high linearity over long periods of time. The stability of ion source conditions is governed by several design aspects:

- the electrostatic potentials applied to the different lenses need to be stable to about $2 \cdot 10^{-5}$.
- The accelerating potential must have a similar stability. Any ripple on top of this voltage leads to a reduction in the steepness of the peak flanks.
- Insulating surface layers that could lead to a charging up of surfaces in the ion source need to be strictly avoided. If such surface layers build up over time, it is necessary to clean the ion source.

38.4 Separation and Detection of Ions in the Mass Spectrometer

38.4.1 Magnetic sectors

High precision isotope ratio mass spectrometers employ magnetic sectors for the separation of ions almost exclusively. Both permanent magnets and electromagnets are used in commercial instrumentation. The ions normally possess a kinetic energy between 2.5 and 10 keV, varying from instrument to instrument. Smaller instruments have lower acceleration potentials and smaller magnets. Larger instruments with higher accelerating voltage have higher sensitivities, higher resolutions and better peak shapes than instruments with lower accelerating voltages, all other things being equal. Ions entering a homogeneous magnetic field are deflected perpendicular to their flight direction and perpendicular to the magnetic field according to the Lorentzian rule. The result is a circular path with the radius:

$$r = 1/B \cdot \sqrt{(2mU/ze)} \quad [38.4]$$

with B being the magnetic field, e is the elementary charge ($= 1.6 \cdot 10^{-19}$ Coulomb), z is the number of charges, U is the accelerating potential and m is the mass of the ion. As an example, a singly charged ion of 44 amu ($=$ atomic mass units or Daltons) that has been accelerated to 5 keV will describe a radius of 13.5 cm when travelling through a homogeneous magnetic field of 0.5 Tesla. It should be noted that mass and translational energy are equivalent in equation [38.4]. Any inhomogeneity of the kinetic energy of the ion beam will lead to a broadening of the ion image at the detector. This is especially important in light of the discussion above about the necessity to suppress ion-molecule reactions by applying a high draw out field to the ionization chamber. The effect is more severe for smaller mass spectrometers since the relative energy spread $\Delta E/U$ is larger for lower acceleration potentials U . For high precision molecular mass determination in organic mass spectrometry, double focusing arrangements that reverse the dispersion due to the energy spread are commonly used (Mattauch & Herzog, 1934; Dempster, 1935).

Early design isotope ratio mass spectrometers had the ions entering the magnetic field perpendicular to the field boundaries (Figure 38.3). The magnet angle (hence the term sector) was either 60° , a design based on the early mass spectrometer proposed by A.O. Nier (Nier, 1940), or 90° which allowed similar ion optical properties (Herzog, 1936) to be realized in an instrument with a smaller footprint. These mass spectrometers were characterized by single direction focusing properties and 1:1 imaging.

A magnetic sector can be treated like an optical prism in geometrical optics: Monoenergetic ions of different mass are dispersed through the magnetic field. Light ions follow a path with a small radius whereas heavier ions describe circular paths with larger radii. Ions with identical mass coming from a focal point with a certain lateral spread α will be focused again after exiting the magnet. The focal points of different masses lie on a focal plane. When entrance and exit drift lengths are identical, the image at the detector plane will be the same size as the original beam at the entrance slit.

Unfortunately, the focusing properties apply only in the x-direction, the direction of the deflection of the ion beam. In the y-direction (along the height of the slit) no focusing takes place (Figure 38.3). As a consequence, the early mass spectrometers had a transmission considerably smaller than unity. Other deleterious effects of not having y-focusing include ions striking the flight tube in the y-direction, which leads to an accumulation of static charge on the surface of the flight tube which can deteriorate peak shapes of the ion beams; ions that are partially reflected can be deflected further in an unpredictable manner. They may also enter the wrong detectors. Secondary electrons released in scattering events can reach the detectors where they create false

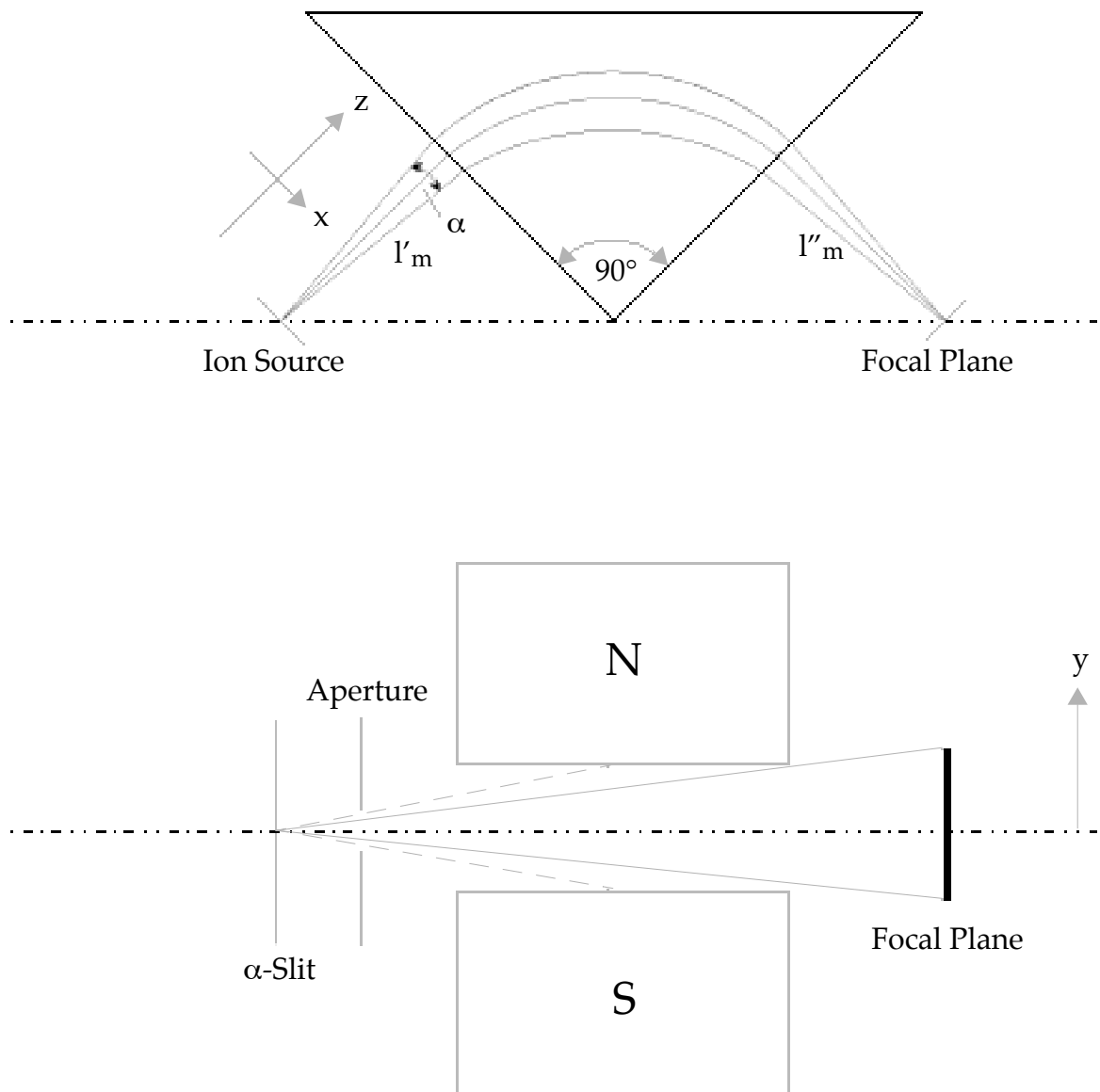

Figure 38.3 - Schematic representation of a 90° magnetic sector mass spectrometer for isotope ratio measurements. In case of equal length of l'_m and l''_m the image width at the focal plane is identical to the width of the entrance slit. However, in y-direction no focusing takes place.

currents. An additional last disadvantage is that the detector entrances in the y -direction are smaller than the ion beams, so that beam fluctuations can lead to reduced precision.

All of these limitations were largely overcome with the introduction of "double direction" or stigmatic focusing, first proposed in 1951 (Cross, 1951)(Figure 38.4), in which the ions enter and exit the magnet at an offset of 26.5° from normal entry. In this case, the fringing field of the magnet at the pole gap acts as a focusing element in the y -direction leading to coincidence of the focus in y - and x -directions. The first commercial isotope ratio instrument to employ stigmatic focusing was the MAT 250 intro-

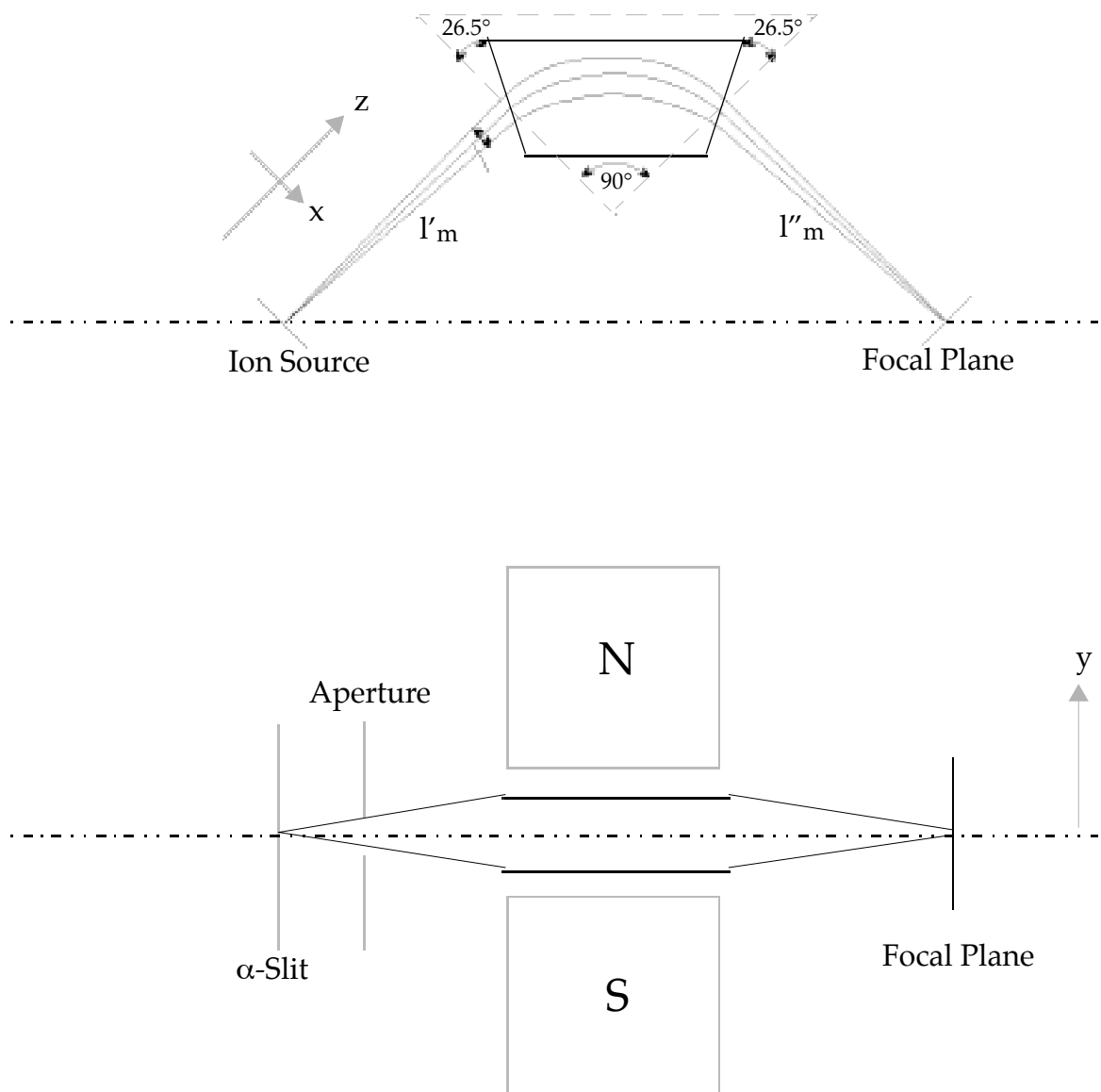

Figure 38.4 - Illustration of the effect of 'Stigmatic Focusing'. A non-normal entry and exit of the ions of 26.5° provides double direction focusing at the focal plane. The fringing fields at the magnet gap act as focusing elements in y -direction. No ions are lost to the walls, so transmission of close to 100% is possible.

duced in 1977; today, almost all commercial instruments have incorporated it in some way.

The choice between a permanent magnet and an electromagnet needs to be discussed in terms of the limitations that a particular choice imposes on the analytical performance. From a theoretical (i.e. ion optical) point of view, both types of magnets are identical. However, permanent magnets often do not reach the same homogeneity as electromagnets. In practice, the difference between the two types of magnets shows up in the way a particular mass is selected. The field of an electromagnet may be changed by applying a variable current to the coils thus allowing a scan of the complete mass spectrum (equation [38-4]). Because the field of a permanent magnet cannot be changed, mass selection is made by altering the accelerating voltage. Usually, the magnetic field strength of a permanent magnet mass spectrometer is selected to ensure that the isotopes of nitrogen can be measured with an accelerating voltage close to the maximum (e.g. 5 kV). Then, the CO_2^+ isotope triplet can be brought into focus with $28/44 \cdot 5\text{kV} = 3.18\text{ kV}$. For SO_2 , the voltage must be lowered even further to 2.19 kV. As a consequence of reducing the accelerating voltage for mass selection, the sensitivity and the focusing conditions of the ion source change with mass. Because the isotopes of nitrogen are measured at the maximum accelerating voltage, ions with masses lower than 28 cannot be measured in such a system. This is quite unfortunate because water, mass 18, is a potent source for protonation in the ion source and should be routinely monitored (Leckrone & Hayes, 1998). This is of particular importance for the isotopic characterization of water. The isotopes of hydrogen are measured on H_2 , hydrogen gas (masses 2 and 3), on a 'spur' which can not access mass 18 either. Incomplete conversion can lead to contamination of the ion source with water and the formation of extra H_3^+ . In the case of CO_2 , water contributes to an isobaric interference at mass 45 through formation of CO_2H^+ . When on-line high temperature pyrolysis is used for sample conversion (Burgoyne & Hayes, 1998) mass 15 is indicative of CH_4 formation. Methane is also a very potent source for protonation. Therefore, it needs to be monitored routinely in order to avoid its presence in the ion source.

38.4.2 Multiple Faraday Cup Detectors

The use of multiple detectors to simultaneously monitor and integrate the ion currents of interest was introduced by A.O. Nier in 1947. Two ion currents, e.g. masses 44 and 45 from CO_2 , hit a collector plate mounted behind a grounded slit and a pair of secondary electron suppressor shields. The advantage of the simultaneous measurement with two separate amplifiers is that fluctuations of the ion currents due to temperature changes, electron beam instability etc. cancel completely. The magnet and the accelerating voltage remain constant. No peak jumping is required, which eliminates the corresponding settling times. Moreover, each detector channel can be fitted with a high ohmic resistor appropriate for the mean natural abundance of the isotope ion current of interest. This principle of static multicollection is still in use but the collector plate has been replaced by deep Faraday cups, in order to minimize false detector currents generated from secondary electrons. The interior of the Faraday cups are sometimes lined with graphite in order to minimize errors arising from reflections

and sputtering effects. Modern isotope ratio mass spectrometers have at least three Faraday collectors. For CO₂, the mass 46 collector gathers, almost exclusively, the ¹⁸O information whereas the mass 45 collector has a contribution from both ¹³C and ¹⁷O. In order to measure the ¹³C/¹²C ratios of CO₂, three collectors are necessary, because the ¹⁷O correction is made from the measured δ¹⁸O value and the known terrestrial relation of the two oxygen isotopes (Craig, 1957).

The Faraday cups are carefully positioned along the focal plane of the mass spectrometer. Because the spacing between adjacent peaks changes with mass, and because the scale is not linear, each set of isotopes requires its own set of Faraday cups. A compromise can be employed by making the outer two cups wider in order to cover the dispersion range between the N₂ and the CO₂ triplet (Figure 38.5). No obvious deterioration in performance resulting from this compromise positioning of the Faraday cups has been detected yet. Alternatively, the Faraday cups can be made moveable by mounting them on a variable support which allows the cup positions to be adjusted to the relative positions of the ions. Here, special care needs to be taken to shield the Faraday cups and their leads from stray electrons.

38.5 Instrumental effects requiring correction

Despite continuing efforts to improve mass spectrometer hardware, high precision and high accuracy determination of isotope ratios from samples with terrestrial isotope abundance still requires that a number of corrections be made.

38.5.1 H₃⁺ factor

Mass 3 forms during the analysis of H₂ gas via the ion-molecule reaction:



From reaction [38.5] it can be seen that the amount of H₃⁺ formed is directly proportional to the number of neutral H₂ molecules and to the number of H₂⁺• ions, which for a given sensitivity, is also directly proportional to the number of H₂ molecules in the ion source.

Thus:

$$[\text{H}_3^+] = k_1 \cdot [\text{H}_2]^2 \quad [38.6]$$

With the ion current ratio expressed as ${}^3\text{R} = \{[\text{H}_3^+] + [\text{HD}^+]\} / [\text{H}_2^+]$ and substituting we have:

$${}^3\text{R} = [\text{HD}^+] / [\text{H}_2^+] + k_2 \cdot [\text{H}_2^+] \quad [38.7]$$

with k_2 being the H₃⁺ factor. Thus, ${}^3\text{R}$ is a linear function of the mass 2 ion current. By measuring ${}^3\text{R}$ with varying amounts of H₂ flowing into the mass spectrometer, k_2 can

Universal Triple Faraday Cup Layout

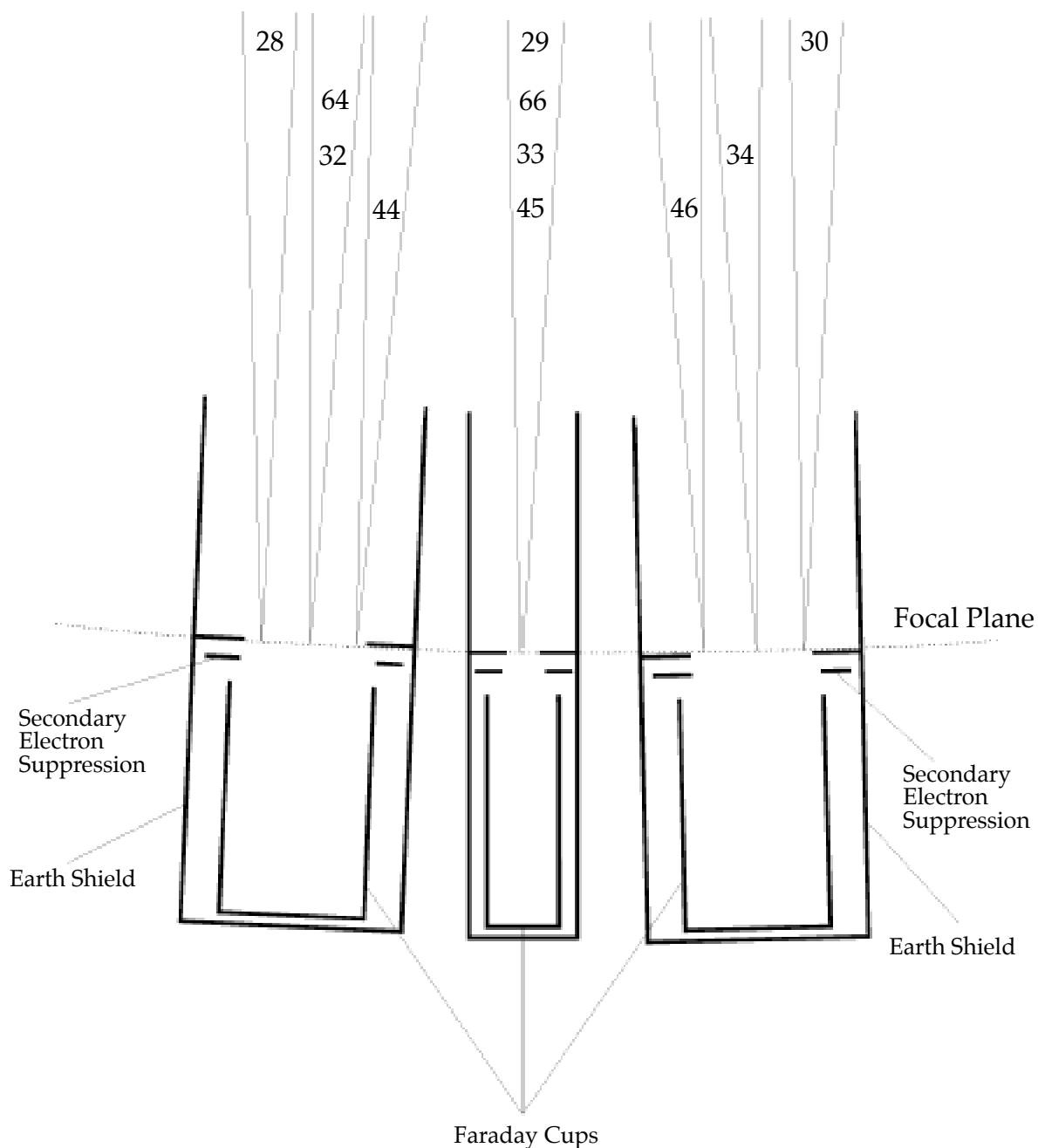

Figure 38.5 - Schematical arrangement of Faraday cups positioned along the focal plane of an isotope ratio mass spectrometer. The two outer cups are wider than the middle cup in order to accommodate a wider dispersion range. The isotopomer triplets of CO₂ (44-46), O₂ (32-34), SO₂ (64, 66) and N₂ or CO (28-30) can be measured with the same set of Faraday cups.

be determined. Usually, k_2 is about 10 ppm/nA, the units being selected to allow convenient comparison with the measured ion currents. The international standard water VSMOW has 156 ppm of deuterium, so the HD⁺ ion current is 312 ppm of the total current. For a typical mass 2 ion current of 5 nA, the contribution of [H₃⁺] to the total mass 3 ion current is 50 ppm. Thus, the H₃⁺ ion current measured for H₂ from VSMOW is 16% of the true mass 3 ion current, that which represents the deuterium content of the sample. Clearly the H₃⁺ factor must be rather constant during a series of measurements if determination of the D/H ratios is to be made with a precision <0.5 per mill.

This discussion assumes that the original content of deuterium in the sample is available in the hydrogen gas for analysis. For water reduction methods, this is usually true. However, when H₂ gas is equilibrated with water in the presence of a platinum catalyst (Horita, 1988), the equilibrium fractionation factor between H₂ and H₂O dictates that at 25°C the H₂ gas will have only 25% of the deuterium concentration in the liquid. Hydrogen gas equilibrated with VSMOW thus has only 39 ppm of deuterium or 78 ppm HD (= -750 ‰ !) resulting in an HD⁺ ion current of $4 \cdot 10^{-13}$ A (mass 2 current 5 nA) which needs to be measured with a precision of better than 10⁻³. The requirement for a stable H₃⁺ factor is consequently enhanced by a factor of four relative to analysis of H₂ from water reduction.

Because the H₃⁺ factor cannot be determined with the precision required for isotope ratio determination, it is advisable to measure a series of samples with the same H₃⁺ factor. This has the advantage that errors in the precise knowledge of the H₃⁺ factor can be corrected for by scaling, i.e. adjusting the measured differences to the known difference of a pair of standards, in general SLAP and VSMOW (Coplen, 1988).

38.5.2 Scaling of δ values

Scaling is mandatory for hydrogen and oxygen isotope ratio determination (Coplen, 1988) mainly because of difficulties and inconsistencies in sample preparation. However, it has been shown in a recent laboratory intercomparison study (Brand & Coplen, 2001) using pure hydrogen gas (i.e., there was no sample preparation) that adjustment of measured differences to precisely known differences is also required to correct for instrumental artifacts. These can have many causes including non-perfect removal of the H₃⁺ contribution, errors in determining the hydrogen background¹, predispersion at the ion entry into the mass spectrometer etc. The effects are particularly important for D/H measurements due to the large relative mass difference between HH and HD, but the need to have laboratories intercalibrated at high levels of precision points to an increasing need for scaling of measured δ values for gases other than H₂.

1. Hydrogen gas dissolves in the rotary pump oil. It can diffuse back into the mass spectrometer due to an insufficient compression ratio of the turbo pump. This effect may vary with time.

38.5.3 Abundance Sensitivity

Abundance sensitivity refers to the contribution at one mass arising from an ion current at the neighboring mass. The contribution from the mass 44 ion current to mass 45 can be treated with:

$$i_{\text{meas}} = i_{\text{true}} + i_{\text{ab.sens.}} \quad [38.8]$$

or $I_{\text{true}} = i_{\text{meas}} (1-a)$ with a representing the portion of the ion current that is generated through the abundance sensitivity effect.

Inserting into the δ -equation [38.1] and transforming yields:

$$\delta = (R_{\text{sa}} - R_{\text{st}}) / (R_{\text{st}} + a) \cdot 1000 \quad [38.9]$$

For modern isotope ratio mass spectrometers operating at pressures in the analyzer of better than 10^{-7} mbar, abundance sensitivity usually is $<10^{-5}$ on mass 45. Its value is influenced by the ion optical properties of the instrument. Large dispersion here means small abundance sensitivity. Careful alignment of the magnet and thus peak shapes optimized for best flank steepness help keeping the abundance sensitivity small.

For an abundance sensitivity value $a = 10^{-5}$ the difference between equation [38.1] and equation [38.9] amounts to 10^{-3} per mill and can thus be neglected safely. However, if abundance sensitivity increases by one or two orders of magnitude, as can be the case in on-line measurements of isotope ratios, it cannot be neglected (see below).

38.5.4 Linearity Correction

The precision of a measurement using the changeover technique often depends upon the quality of the pressure matching between the variable bellows reservoirs. This is especially the case when the mass spectrometer is not operating in the optimum range for linearity. This may occur when the application of a high drawout potential results in a drop in sensitivity that cannot be tolerated. Alternatively, the sample preparation may simply fail to provide the required cleanliness of the sample. It may also be caused by design deficiencies of the ion source causing physical non-linearities. In such cases, a linearity correction can improve the results, provided the conditions are monitored carefully and are sufficiently described by a linear relationship between the major ion current and the measured isotopic ratio. When fully applied the correction is similar to the H_3^+ correction; the measured ratios of both sample and reference gas are corrected, being normalized to an identical major ion current before the δ value is calculated. A simplified correction works as follows: If the measured non-linearity Δ of the ratio is given in $\% / \text{nA}$, then the correction to be applied to the final result is:

$$\delta_{\text{corr}} = \delta_{\text{meas}} - \Delta \cdot (i_{\text{sa}} - i_{\text{ref}}) \quad [38.10]$$

As an example, the measured δ value is +10‰. The reference gas has been measured with a major beam intensity of 5 nA, the sample gas with 3 nA. The non-linearity of the mass spectrometer was determined as +0.1‰/nA. Then the corrected δ value is 10.20‰.

38.5.5 Background correction

In isotope ratio mass spectrometry, the background has two components: an electronic offset usually referred to as baseline and a chemical part that represents the ion current on the mass positions of interest when there is no gas added to the mass spectrometer (the blank).

The treatment of the background is normally taken care of by the mass spectrometer operating software. The standard technique is to measure a background during a routine measurement by first closing the changeover valve to the mass spectrometer and then waiting an appropriate time for the gas to be pumped away. After this the residual signal is measured. This signal is then stored and taken as background for the subsequent measurements until the next background measurement overrides the previous one. This standard procedure relies on a small and stable background condition and on an assumed ideal balance of ion currents between sample and reference gas. The errors associated with a false background determination are small: of the order 0.01 per mill.

38.5.6 Memory effects

In general memory effects can occur during the automated or manual preparation of the measurement gases. They are particularly important when the sample material is water or carbonate (especially when the carbonates are reacted in a common acid vessel). But when the samples differ considerably from natural isotopic abundance, i.e. in tracer studies, almost every preparation is prone to memory effects. Each sample preparation method thus needs to be checked carefully and quantitatively for such artifacts. If necessary, a mass balance correction can be applied that assumes a certain percentage of the measured total ion current i_{meas} is due to the previous sample:

$$\delta S_a = (\delta_{\text{meas}} \cdot i_{\text{meas}} - \delta_{\text{mem}} \cdot i_{\text{mem}}) / (i_{\text{meas}} - i_{\text{mem}}) \quad [38.11]$$

with i_{mem} = proportion of memory signal, e.g. for a memory of 2%, $i_{\text{mem}} = 0.02 \cdot i_{\text{meas}}$. Equation [38.11] assumes that the samples are similar in size, otherwise i_{mem} needs to be evaluated from the integrated ion current of the previous sample.

In practice, memory effects are tested by measuring two samples of sufficiently different isotopic composition in series, e.g. 5 times sample *a* followed by 5 times sample *b*, and watching the transition between them. Applying equation [38.11] should give a quantitative correction to the data. If necessary, several of the previous samples need to be considered.

38.5.7 Isobaric interferences

Isobaric interferences are ion currents in Faraday cups that belong to ionic species other than those being examined. The most prominent examples are the aforementioned correction for the ^{17}O moiety at mass 45 of CO_2 and the correction for the H_3^+ contribution to the mass 3 ion current. Other isobaric interferences and contributions include:

- ^{17}O and ^{13}C on mass 46 of CO_2
- CO^+ interference on mass 28 when measuring nitrogen
- N_2 interference on mass 28 when measuring ^{18}O on line on the CO masses 30 and 28
- N_2O interference on the masses 44, 45 and 46, and
- ^{18}O and ^{17}O contributions on masses 66 and 65 of SO_2 .

The corrections for interferences that are due to another isotopic form of the sample gas have been discussed in the literature¹. A detailed discussion is not presented here.

38.6 Instrumental aspects of isotope ratio monitoring ('irm')

Isotope ratio monitoring ('irm')(Matthews & Hayes, 1978) is a relatively recent innovation in isotope ratio mass spectrometry (Brand, 1996) which does not require the use of the dual inlet system or the Changeover Valve. This is possible because the requirement for viscous flow is achieved by transporting the sample gas into the mass spectrometer entrained in a stream of helium carrier gas. Isotope ratio monitoring is ideally suited for the coupling of chromatographic techniques with isotope ratio mass spectrometers. The sample size required for an isotope ratio measurement is dramatically reduced, with reported lower limits in the low picomolar range (Merritt & Hayes, 1994). The traditional dual inlet system approach which served isotope mass spectrometers well for many years can not be adapted to handle on-line chromatography for a number of reasons:

- Ion currents are measured in the order in which they emerge from a GC column, without significant capability of modifying their intensities relative to a reference gas. A linear response of the entire mass spectrometer system is therefore of utmost importance.
- The time for measurement of the isotopic signals is restricted by the width of the chromatographic peak. For good gas chromatography (which means sharply defined narrow peaks), this can mean less than 5 seconds.
- All signal intensities vary in time. The mass spectrometer must be capable of handling transient signals (Brand, 1998) acquired on multiple channels.
- It must be possible to measure the analytical ion currents in a large surplus of He carrier gas without loss in precision for the isotope ratio determination. This is of particular importance for hydrogen isotope measurements.
- Absolute sensitivity is much more important than with the dual inlet system. Standard gas chromatographic techniques with capillary columns have capacity limits that require high sample utilization. Because it is the total number of ions containing

1. For a recent comprehensive discussion see: IAEA-TECDOC-825, 'Reference and intercomparison materials for stable isotopes of light elements', IAEA, Vienna 1995, ISSN 1011-4289.

the minor isotope that determines the statistical limit of precision (Merritt & Hayes, 1994), and because sample sizes required for good chromatography are significantly smaller than for the dual inlet system, it is important to achieve the highest level of sample usage possible, within the constraints of linear response.

- Chromatography not only separates different chemical species. It even separates at the level of isotopomers, i.e. molecules with identical chemical composition but different isotopic content (Gunter & Gleason, 1971; Brand, 1996). For carbon, the ^{13}C -bearing compounds generally precede the ^{12}C only compounds by 50 to 300 msec. This isotopic separation within the GC column means that the isotopic composition of a compound will vary across the peak after elution, which has extremely significant consequences for data acquisition, background determination, and data reduction.
- The long term stability is important, at least for the time it takes for the compounds of interest to elute from the chromatographic column. Often, the chromatograms have a huge number of peaks, making the proper timing of reference gas pulses difficult.

In order to cope with the new requirements, a new generation of mass spectrometers has been designed with a number of features that specifically address the challenges of isotope ratio monitoring. Because abundance sensitivity becomes an issue due to the high load of He carrier gas, differential pumping¹ has been introduced to alleviate this problem considerably. A special problem in measuring hydrogen isotope ratios is caused by tailing of large mass 4 ($\text{He}^+\bullet$) onto the mass 3 channel. This tail is so large that it saturates the HD channel. The problem has been solved only recently by measuring the hydrogen ion currents with a large dispersion (Prosser & Scrimgeour, 1995) to increase the abundance sensitivity and, at the same time, use an energy discrimination filter in order to prevent ions of lower than nominal energy from entering the mass 3 Faraday cup (Hilkert et al., 1999).

The fast flow of data and the fact that the isotopomers are separated in time through chromatography means that peaks cannot be sampled partially without sacrificing precision and accuracy. Rather, uninterrupted, continuous integration of all ion signals over the entire chromatographic peak is required. Isotope ratio monitoring mass spectrometers have the means for handling such transient signals in a quantitative manner. Both sensitivity and linearity need to be optimized simultaneously. Sensitivity should be better than 2000 molecules per ion reaching the detector and, at the same time, linearity should be better than 0.1 ‰ / nA.

Contrary to the dual inlet system, standardization in isotope ratio monitoring measurements should be done exclusively using the principle of 'Identical Treatment of reference and sample material' or 'IT Principle'. Mostly, isotopic referencing is made with a co-injected peak

1. Differential pumping is achieved by dividing the recipient into two separate volumes individually pumped by two high vacuum pumps. The opening for having ions pass between the volumes should be made as small as possible in order to achieve a high difference in working pressure. Typically, the pressure in the flight tube and detector section should be a factor of 10 lower than the pressure in the ion source region.

of standard gas (Merritt *et al.*, 1994). However, the analytical history of the sample is more complex. In order to avoid systematic errors, isotope reference materials must be run frequently between sample runs thus rendering the standard gas pulses a mediator between the different chromatograms, including the reference runs. Alternatively, reference compounds may be added to the sample solution, provided there is no chromatographic interference when the reference peak elutes (internal referencing).

38.7 Statistical limits to precision

Although the number of ions sampled for isotope ratio evaluation is larger than state-of-the-art counting techniques are able to resolve, the basic process still is that of counting of particles. The counting of ions follows the laws of Poisson statistics (Matthews & Hayes, 1978; Merritt & Hayes, 1994) where the limit of precision is given by:

$$1\sigma = 1/\sqrt{N} \quad [38.12]$$

with N being the number of ions counted or sampled. As an example, a peak of 10 sec width and 10 nA maximum intensity has a total charge of about 50 nAsec or $3 \cdot 10^{11}$ ions. Out of those, about $3 \cdot 10^9$ ions contain the ^{13}C isotopic information. Thus, such peak can be measured with a precision of $2 \cdot 10^{-5}$ or 0.02‰. A reference peak suffers from similar limitations, and also the major ion beams play a small role. Therefore, the statistical limit is about 0.05‰, rather close to the typical goal of the measurement of about 0.1 per mill.

38.8 Conversion equations for isotope ratio reporting

Isotope ratios are generally expressed as deviations from a reference value (equation [38.1]), not as absolute ratios. The reason behind this practice is that relative measurements can be made rather precisely with moderate efforts whereas absolute measurements are much more difficult to make. Mostly, deviations from international standards are known with a precision that exceeds the absolute knowledge of the isotope abundance ratio of the international standard by more than one order of magnitude.

In practice, measurements are made against a working or laboratory reference that has been calibrated carefully against an international reference material. Thus, the measured delta values need to be converted to another scale before reporting. From equation [38.1] it can be shown that

$$\delta_{\text{Sa/St}} = \delta_{\text{Sa/WS}} + \delta_{\text{WS/St}} + 10^{-3}(\delta_{\text{Sa/WS}} \cdot \delta_{\text{WS/St}}) \quad [38.13]$$

with $\text{WS} = \text{working standard}$, St denoting the international standard material and Sa the measured sample. In a typical measurement series reference compounds are processed the same way as the sample ('IT Principle', see above). In such cases, the term $\delta_{\text{WS/St}}$ is measured in its reverse form, $\delta_{\text{St/WS}}$. It may be easily converted using:

$$\delta_{\text{BA}} = -(1/\delta_{\text{AB}} + 10^{-3})^{-1} \quad [38.14]$$

38.9 Conclusions

Variation of stable isotope ratios in nature mostly are small. They are, however, important tracers that can reveal a wealth of information about processes that are happening or that have happened in the past. In order to read this information, the underlying principles need to be understood, and, most importantly, the measurements need to be made with the appropriate high precision. This has become possible with the development of the special instrumentation now common in the laboratories that have specialized on isotope ratio analysis. In order to measure and maintain high precision, the instruments need to be understood by the analyst in a quantitative way. All instrument designs have their merits and pitfalls which must be weighed in order to produce a consistent set of isotope ratio values. The role of differential pumping, the design principles of inlet systems, and the selection of permanent versus electromagnets have been discussed. The importance of software in dealing with ion corrections, the need for quantitative integration of transient signals, and the importance of recognizing and mitigating ion molecule chemistry all have been stressed in this contribution.

The future in isotope ratio mass spectrometry clearly belongs to the chromatographic techniques (isotope ratio monitoring, *irm*). The central role of excellent chromatography for high precision data has been pointed out. The best utilization of isotope ratio monitoring techniques will require good working knowledge of chromatography, to ensure the best separations, and good working knowledge of the isotope ratio mass spectrometer, to maintain high precision analysis capability in routine operation on a daily basis.

Acknowledgments

I am indebted to Roland A. Werner and Jon Lloyd for helpful discussions and a critical review of the manuscript. Charles B. Douthitt has improved the first draft considerably with his critical editing of the manuscript. Most of the experience on which this contribution is based was acquired at Finnigan MAT in Bremen, Germany during 14 years working as a designer of mass spectrometric equipment. Here, I am particularly grateful to Karleugen Habfast for the many fruitful discussions and for being a wonderful teacher.

References

- Aston F. W.** (1942) Mass-spectra and isotopes. *Longmans, Green & Co*, NY, 2nd ed.: 276 p.
- Brand W. A.** (1996) High precision isotope ratio monitoring techniques in mass spectrometry. *J. Mass Spectrom.*, 31: 225-235.
- Brand W. A.** (1998) Isotope ratio mass spectrometry: Precision from transient signals. In: *Adv. Mass Spectrom.*, Vol. 14. E. J. Karjalainen, A. E. Hesso, J. E. Jalonen & U. P. Karjalainen(eds.): 655-680.
- Brand W. A. & Coplen T. B.** (2001) An interlaboratory study to test instrument performance of hydrogen dual-inlet isotope-ratio mass spectrometers. *Fresenius J. Anal. Chem.*, 370: 358-362.
- Burgoyne T. W. & Hayes J. M.** (1998) Quantitative production of H₂ by pyrolysis of gas chromatographic effluents. *Anal. Chem.*, 70: 5136-5141.
- Coplen T. B.** (1988) Normalization of oxygen and hydrogen isotope data. *Chem. Geol. (Isot. Geosc. Sect.)*, 72: 293-297.
- Craig H.** (1957) Isotopic standards for carbon and oxygen and correction factors for mass-spectrometric analysis of carbon dioxide. *Geochim. Cosmochim. Acta*, 12: 133-149.
- Cross W. G.** (1951) Two-directional focussing of charged particles with a sector-shaped, uniform magnetic field. *Rev. Sci. Instrum.*, 22: 717-722.
- Dempster A. J.** (1935) New methods in mass spectroscopy. *Proceed. Am. Phil. Soc.*, 75: 755-767.
- Gunter B. D. & Gleason J. D.** (1971) Isotope fractionation during gas chromatographic separations. *J. Chromat. Sci.*, 9: 191-192.
- Habfast K.** (1997) Advanced isotope ratio mass spectrometry I: Magnetic isotope ratio mass spectrometers. In: *Modern isotope ratio mass spectrometry*. I. T. Platzner (ed.). *John Wiley & Sons*, Chichester, UK: 11-82.
- Halsted R. E. & Nier A. O.** (1950) Gas flow through the mass spectrometer viscous leak. *Rev. Sci. Instrum.*, 21: 1019-1021.
- Herzog R.** (1934) Ionic- and electro-optical cylindrical lenses. *Z. Physik*, 89: 447-.
- Hilkert A. W., Douthitt C. B., Schlüter H. J. & Brand W. A.** (1999) Isotope ratio monitoring gas chromatography/mass spectrometry of D/H by high temperature conversion isotope ratio mass spectrometry. *Rapid Commun. Mass Spectrom.*, 13: 1226-1230.
- Honig R. E.** (1945) Gas flow in the mass spectrometer. *J. Appl. Phys.*, 16: 646-654.
- Horita J.** (1988) Hydrogen isotope analysis of natural waters using an H₂-water equilibration method: A special implication to brines. *Chem. Geol. (Isot. Geosci. Sect.)*, 72: 89-94.
- Kiser R. W.** (1965) Introduction to mass spectrometry and its applications. *Prentice Hall*, NY.
- Leckrone K. J. & Hayes J. M.** (1997) Efficiency and temperature dependence of water removal by membrane dryers. *Anal. Chem.*, 69: 911-918. [14]
- Leckrone K. J. & Hayes J. M.** (1998) Water-induced errors in continuous-flow carbon isotope ratio mass spectrometry. *Anal. Chem.*, 70: 2737-2744.
- Mattauch J. & Herzog R.** (1934) Über einen neuen Massenspektographen. *Z. Physik*, 89: 786-795.
- Matthews D. E. & Hayes J. M.** (1978) Isotope-ratio-monitoring gas chromatography-mass spectrometry. *Anal. Chem.*, 50: 1465-1473.
- McKinney C. R., McCrea J. M., Epstein S., Allen H. A. & Urey H. C.** (1950) Improvements in mass spectrometers for the measurement of small differences in isotopic abundance ratios. *Rev. Sci. Instrum.*, 21: 724-730.
- Merritt D. A., Brand W. A. & Hayes J. M.** (1994) Isotope-ratio-monitoring gas chromatography-mass spectrometry: methods for isotopic calibration. *Org. Geochem.*, 21: 573-583.
- Merritt D. A. & Hayes J. M.** (1994) Factors controlling precision and accuracy in isotope-ratio-monitoring mass spectrometry. *Anal. Chem.*, 66(14): 2336-2347.
- Murphy B. F.** (1947) The temperature variation of thermal diffusion factors for binary mixtures of H, D and He. *Phys. Rev.*, 72: 834-837.
- Nier A. O.** (1940) A mass spectrometer for routine isotope abundance measurements. *Rev. Sci. Instrum.*, 11: 212-216.
- Nier A. O.** (1947) A mass spectrometer for isotope and gas analysis. *Rev. Sci. Instrum.*, 18: 398-411.
- Platzner I. T., Habfast K., Walder A. J. & Goetz A.** (1997) *Modern isotope ratio mass spectrometry*. *John Wiley & Sons*, Chichester, West Sussex, England: 514 p.

- Prosser S. J. & Scrimgeour C. M.** (1995) High-precision determination of $^2\text{H}/^1\text{H}$ in H_2 and H_2O by continuous-flow isotope ratio mass spectrometry. *Anal. Chem.*, 67: 1992-1997.
- Thomson J. J.** (1910) Rays of positive electricity. *Philosoph. Mag.*, 20: 752-767.
- Thomson J. J.** (1913) Rays of positive electricity and their application to chemical analyses. *Longman, Green and Co.*, London.
- Valyi L.** (1977) Atom and ion sources. Akademiai Kiado, Budapest.